

TITLE: M50 BATTERY CHARGER

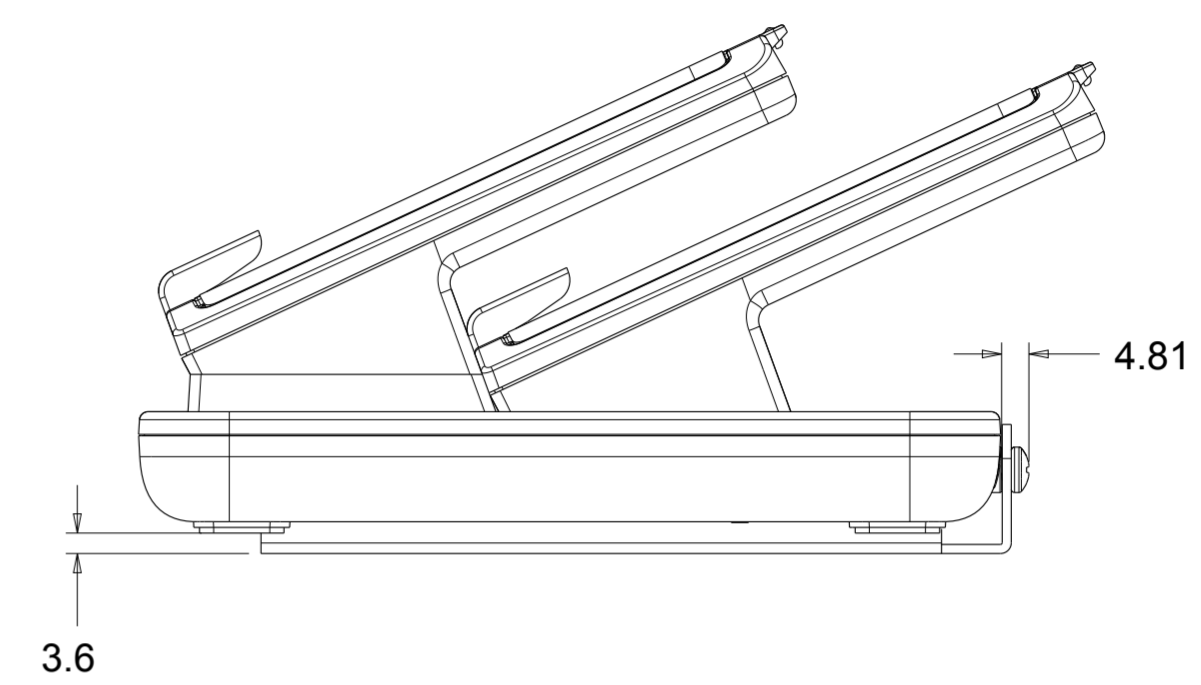

MOUNTING BRACKET USED FOR COUNTER

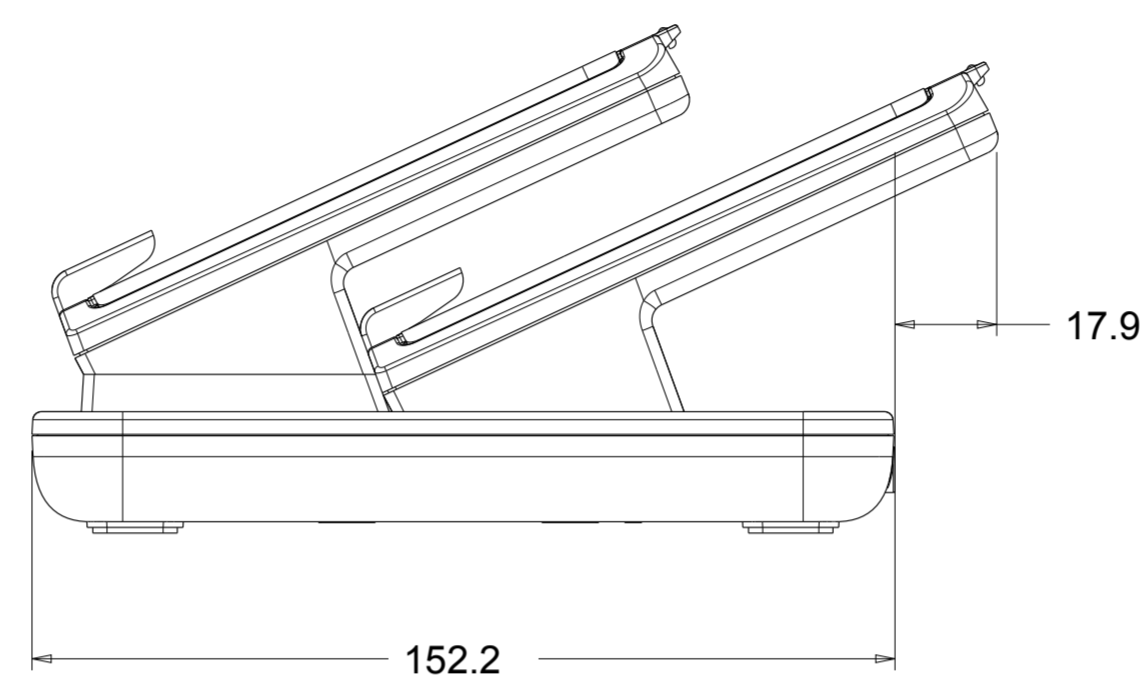
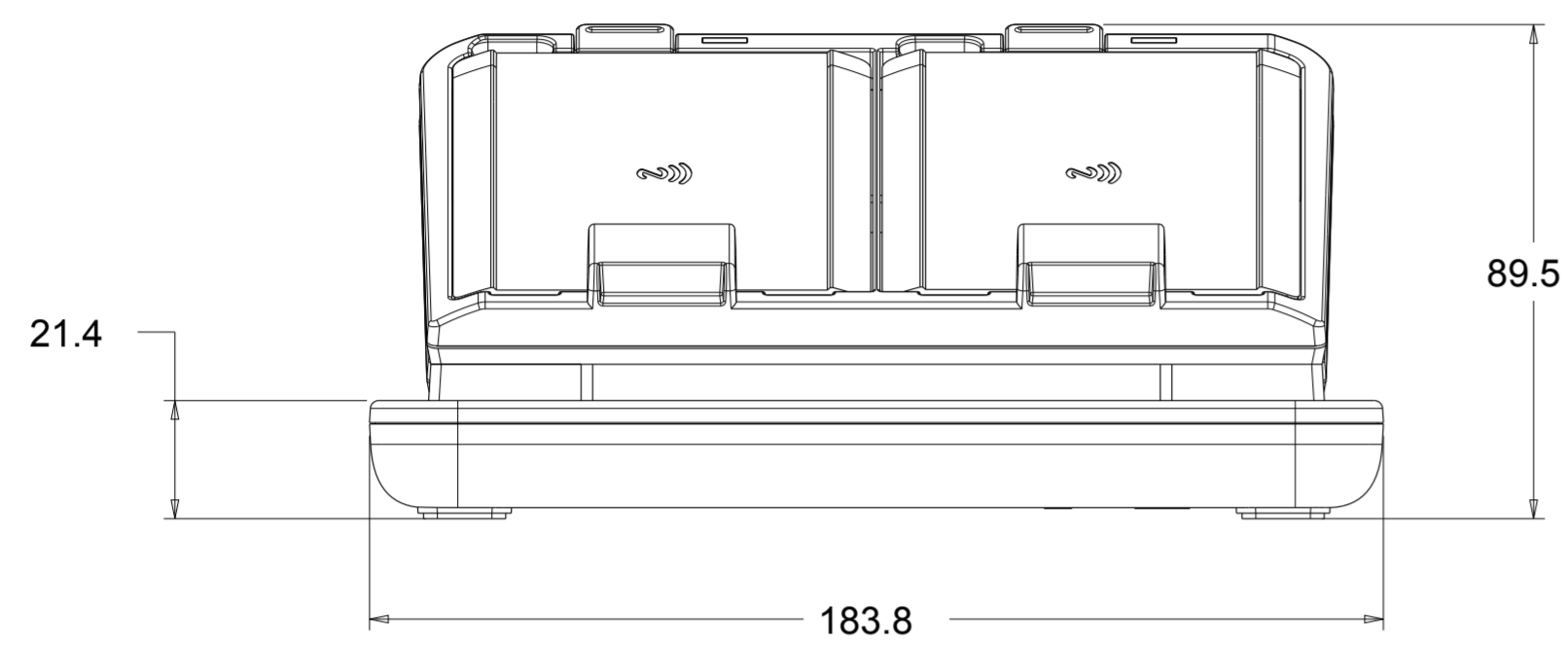
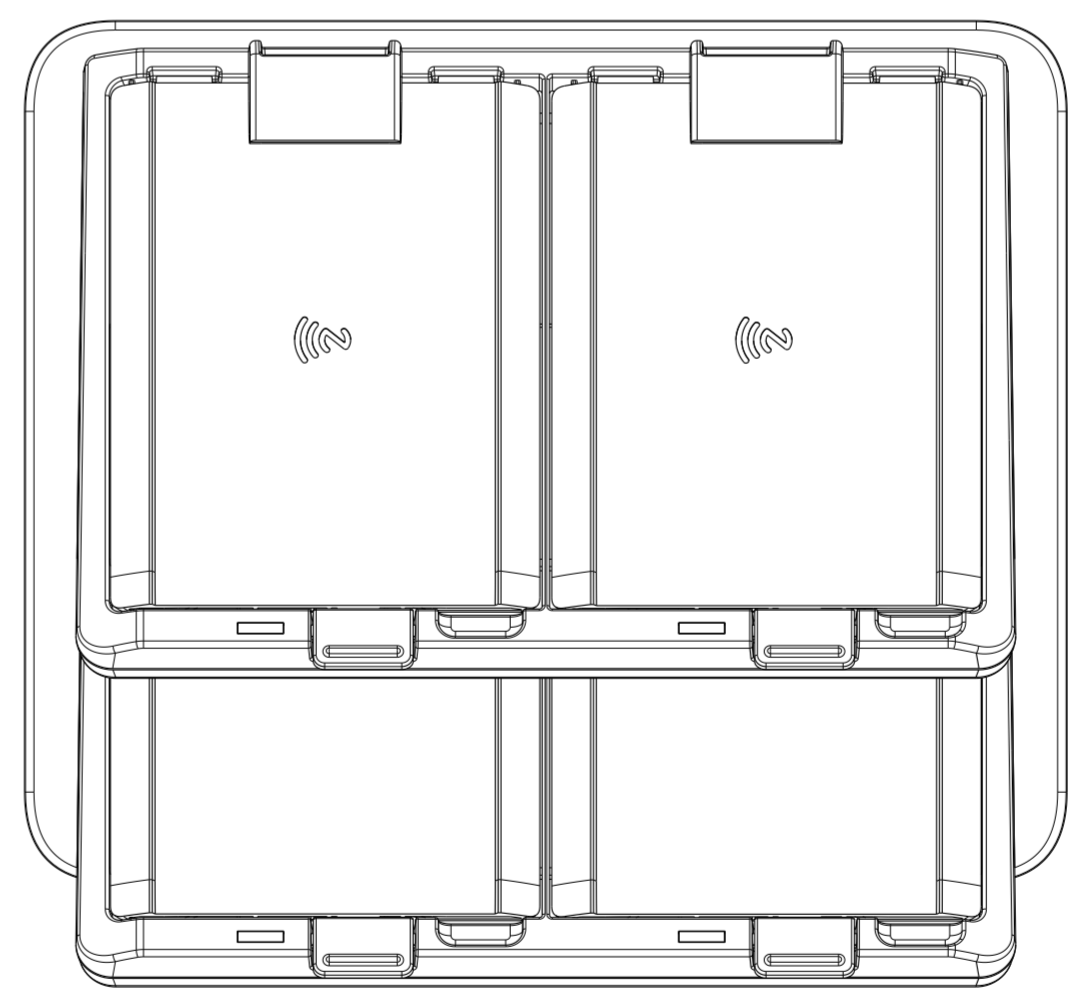
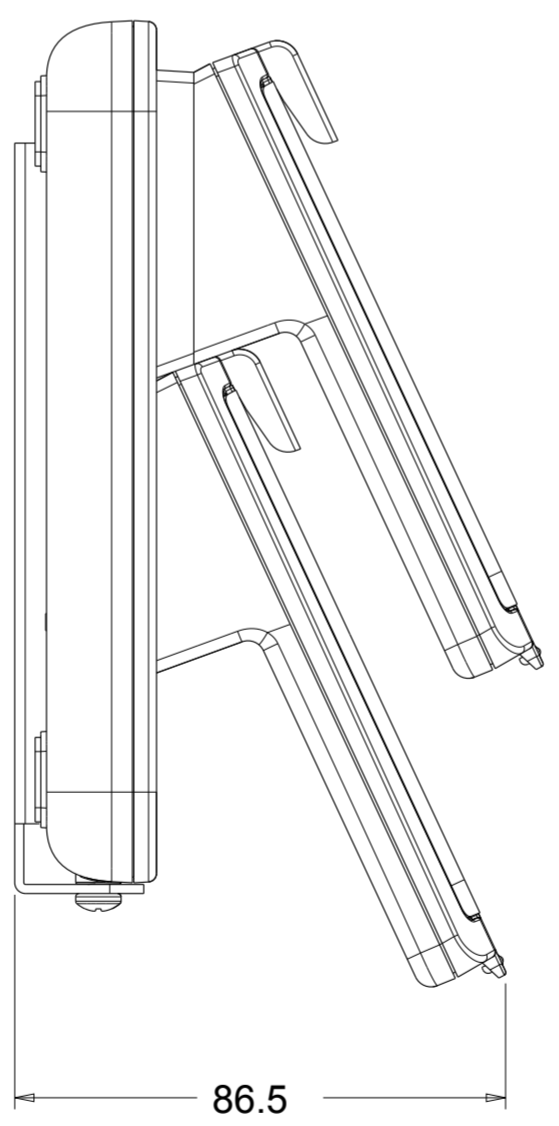
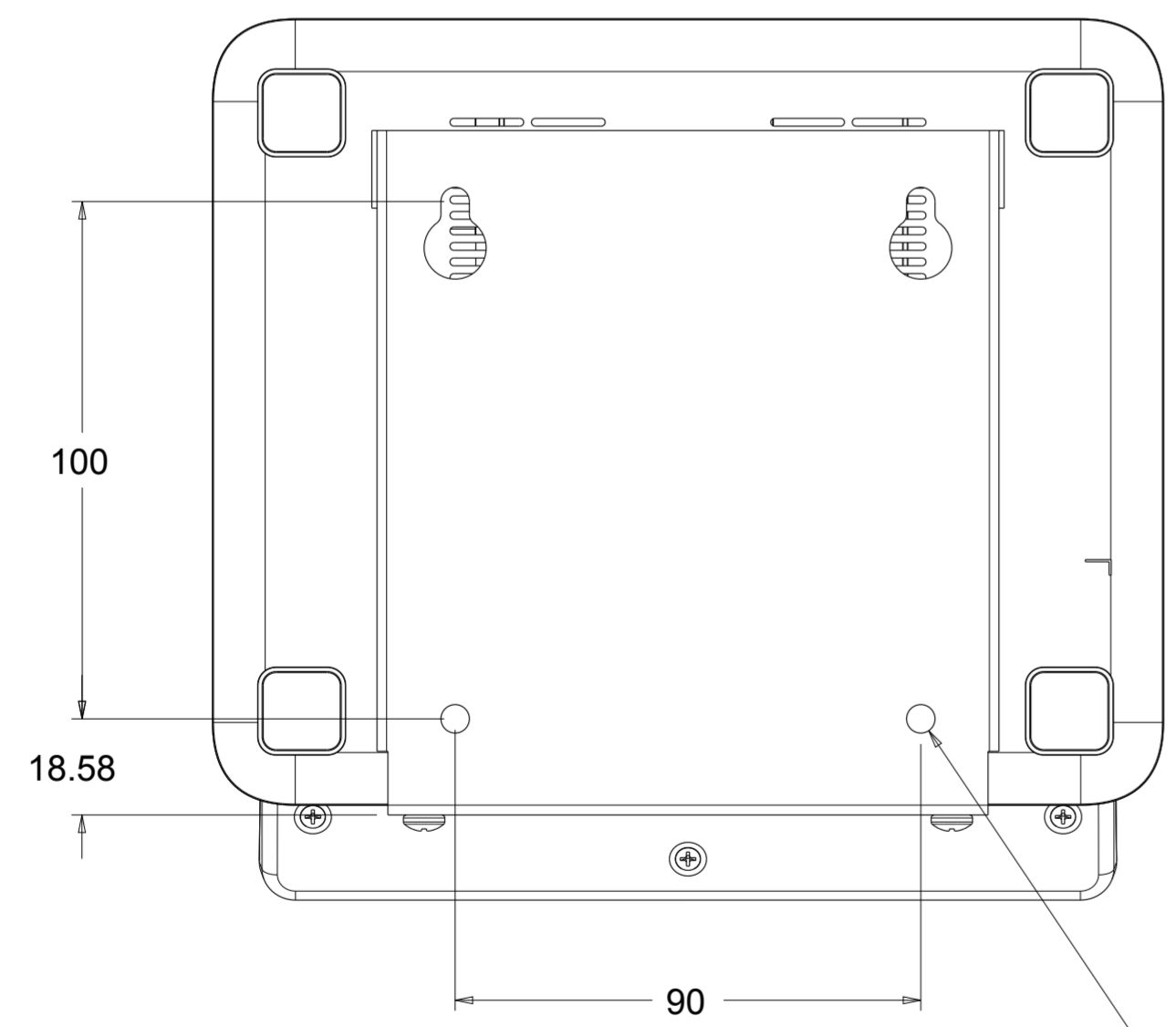

MOUNTING BRACKET USED FOR WALL

Ø 5.5
 SCREWS NOT INCLUDED.
 CHOOSE APPROPRIATE SCREW
 TYPE FOR COUNTER/WALL MATERIAL (X4);
 MAX. SCREW 5mm,
 MAX. HEAD HEIGHT 4mm

DIMENSIONS ARE IN MILLIMETERS