

THIS INFORMATION IS CONFIDENTIAL AND PROPRIETARY TO ELO TOUCH SOLUTIONS. IT MAY NOT BE DISCLOSED TO ANYONE OTHER THAN ELO TOUCH SOLUTIONS PERSONNEL WITHOUT AUTHORIZATION FROM ELO TOUCH SOLUTIONS (www.elotouch.com).

REVISIONS					
REV	ZONE	BY	DESCRIPTION	DATE	APPROVED
A		BP	FOR INITIAL RELEASE PER CO-18-XXXX	10/22/2018	

NOTES: (UNLESS OTHERWISE SPECIFIED)

1. ALL MATERIAL AND COATINGS TO BE RoHS COMPLIANT.
2. MANUFACTURE INJECTION MOLDED PARTS PER ELO SPEC. ES600462.
3. THE COMPUTER MODEL IS BASIC (THEORETICALLY EXACT). THE PHYSICAL PART MUST LIE WITHIN $\pm .08\text{MM}$ OF THE MODEL, EXCEPT WHERE NOTED.
4. INTERPRET DRAWING PER ASME STANDARD Y-14.5M - 1994.
5. FLASH IS PERMISSIBLE ON PARTING LINE(S) ONLY. FLASH NOT TO EXCEED $.08\text{MM}$ PROTRUSION.
6. GATE, EJECTOR PIN AND PARTING LINE LOCATIONS PER WRITTEN AGREEMENT BY VENDOR AND ELO. GATE PROTRUSIONS NOT TO EXCEED $.08\text{MM}$.
7. LOCATE MATERIAL IDENTIFICATION AND DATE CODE PER WRITTEN AGREEMENT.
8. EXCEPT WHERE SPECIFIED, MAX STEP = 0.2MM

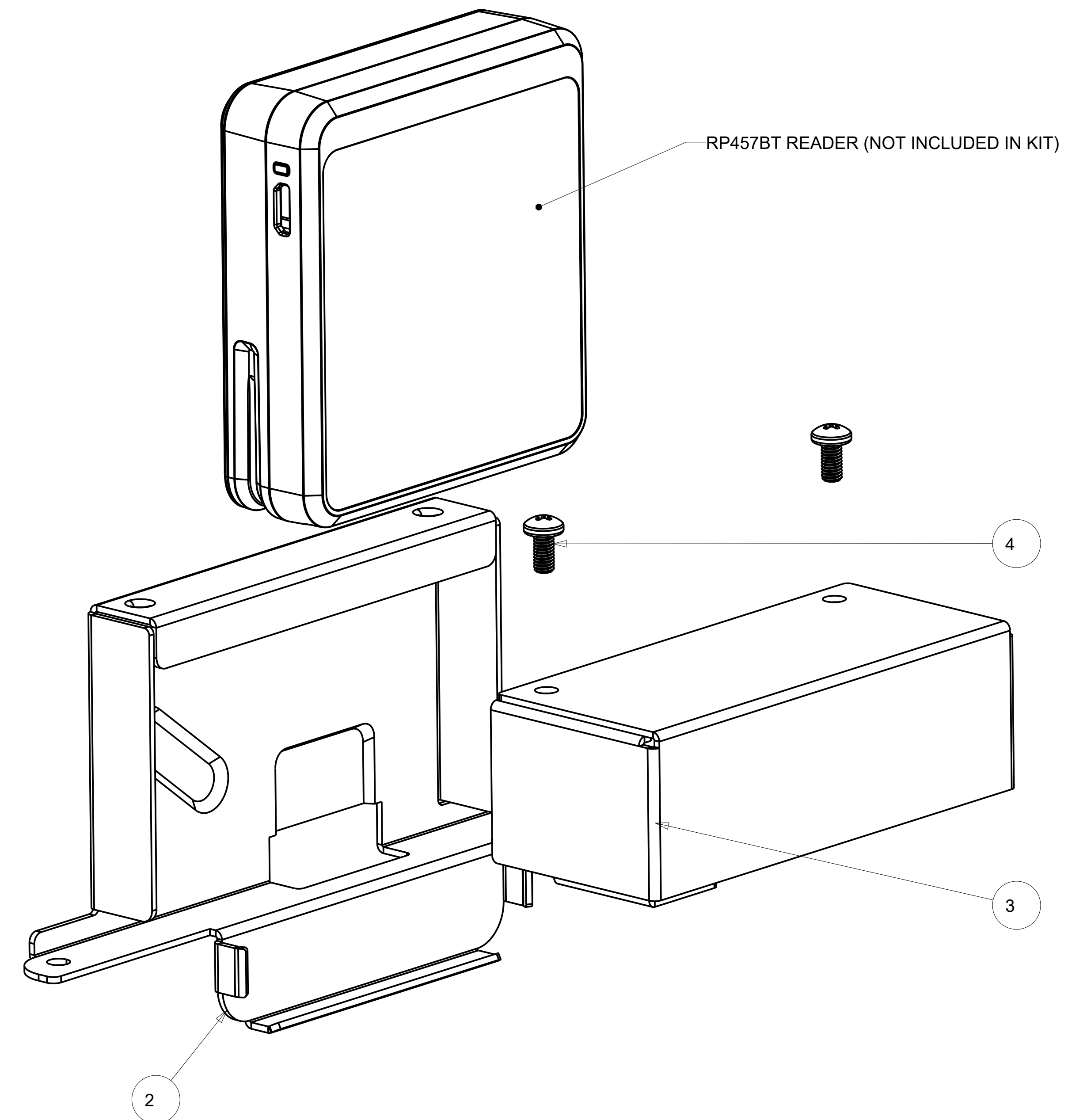

ITEM NO.	QTY REQ'D	DRAWING OR PART NO.	DESCRIPTION	MATERIAL SPECIFICATION
4	2		SCREW_M3X6	
3	1		RP457BT_BRKT_2	
2	1		RP457BT_BRKT_1	
1	1		RP450C_BT	

PART NO.		UNLESS OTHERWISE SPECIFIED ALL DIMENSIONS ARE IN MILLIMETERS		DRAWN B. Perry	DATE 09-May-16	TITLE FILES MECH, 3D, RP457PP		
DO NOT SCALE DRAWING		TOLERANCES ARE: DECIMALS $\pm .25$ ANGLES $\pm 1/2^\circ$ FRACTIONS $\pm 1/32$		CHECK DESIGN	DATE 00.00.00	THIRD ANGLE PROJECTION		
Pro/E prt/asm: RP457BT_MOUNT_TLA.PRT		Pro/E drw: SD608242.DRW		SIZE D	SCALE 2.000	SHEET 1 OF 7	DWG. NO. SD608242	REV A

DWG. NO. SD608242 REV. 3

THIS INFORMATION IS CONFIDENTIAL AND PROPRIETARY TO ELO TOUCH SOLUTIONS. IT MAY NOT BE DISCLOSED TO ANYONE OTHER THAN ELO TOUCH SOLUTIONS PERSONNEL WITHOUT AUTHORIZATION FROM ELO TOUCH SOLUTIONS (www.elotouch.com).

REVISIONS					
REV	ZONE	BY	DESCRIPTION	DATE	APPROVED
1	--	XX	INITIAL RELEASE	10/03/2018	

NOTES: (UNLESS OTHERWISE SPECIFIED)

1. ALL MATERIAL AND COATINGS TO BE RoHS COMPLIANT.
2. MANUFACTURE INJECTION MOLDED PARTS PER ELO SPEC. ES600462.
3. THE COMPUTER MODEL IS BASIC (THEORETICALLY EXACT), THE PHYSICAL PART MUST LIE WITHIN $\triangle .08\text{MM}$ OF THE MODEL, EXCEPT WHERE NOTED.
4. INTERPRET DRAWING PER ASME STANDARD Y-14.5M - 1994.
5. FLASH IS PERMISSIBLE ON PARTING LINE(S) ONLY. FLASH NOT TO EXCEED $.08\text{MM}$ PROTRUSION.
6. GATE, EJECTOR PIN AND PARTING LINE LOCATIONS PER WRITTEN AGREEMENT BY VENDOR AND ELO. GATE PROTRUSIONS NOT TO EXCEED $.08\text{MM}$.
7. LOCATE MATERIAL IDENTIFICATION AND DATE CODE PER WRITTEN AGREEMENT.
8. EXCEPT WHERE SPECIFIED, MAX STEP = 0.2MM

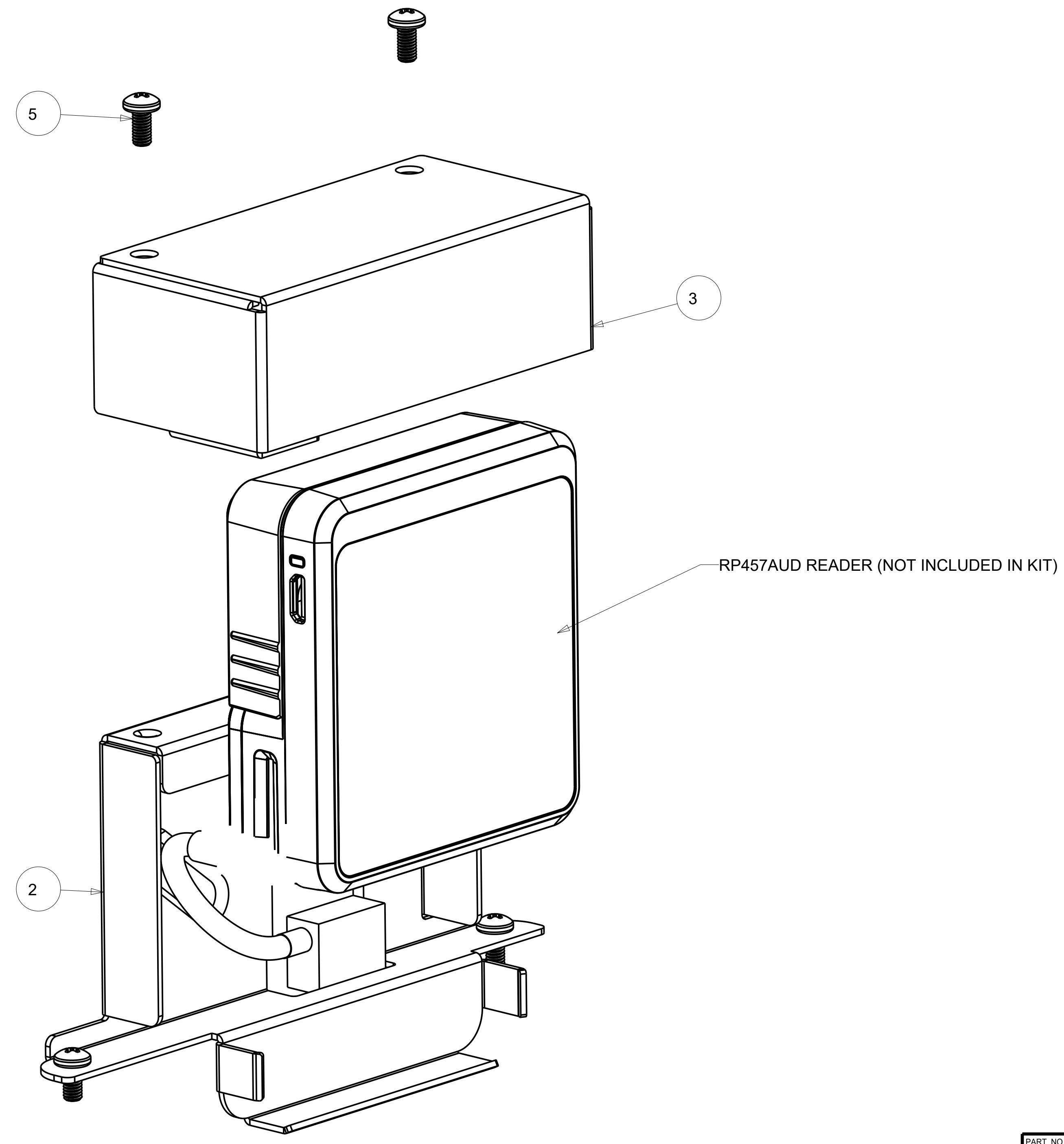

ITEM NO.	QTY REQ'D	DRAWING OR PART NO.	DESCRIPTION	MATERIAL SPECIFICATION
5	4		SCREW_M3X6	
4	1		RP457C_AUD	
3	1		RP457AUD_BRKT_2	
2	1		RP457AUD_BRKT_1	
1	3	EXXXXX	RP457_CABLE	

PART. NO.		UNLESS OTHERWISE SPECIFIED ALL DIMENSIONS ARE IN MILLIMETERS		DRAWN B. Perry	DATE 09/05/2018	TITLE				
METRIC		TOLERANCES ARE: DECIMALS $\pm .25$ ANGLES $\pm 1/2^\circ$ FRACTIONS $\pm 1/32$		CHECK	DATE	FILES MECH, 3D, RP457PP				
DO NOT SCALE DRAWING				DESIGN	DATE 00.00.00					
ProjE: prt/asm: RP457AUDMONITORLARRT				THIRD ANGLE PROJECTION		SIZE D	SCALE 2.000	SHEET 2 OF 7	DWG. NO. SD608242	REV 3

SHEET 2 OF 7 REV 3 DWG. NO. SD608242

THIS INFORMATION IS CONFIDENTIAL AND PROPRIETARY TO ELO TOUCH SOLUTIONS. IT MAY NOT BE DISCLOSED TO ANYONE OTHER THAN ELO TOUCH SOLUTIONS PERSONNEL WITHOUT AUTHORIZATION FROM ELO TOUCH SOLUTIONS (www.elotouch.com).

Filename	Material	Finish	Quantity
RP457BT_BRKT_1.PRT	SECC 1.0T	BLACK PAINT, FINE TEXTURE	1

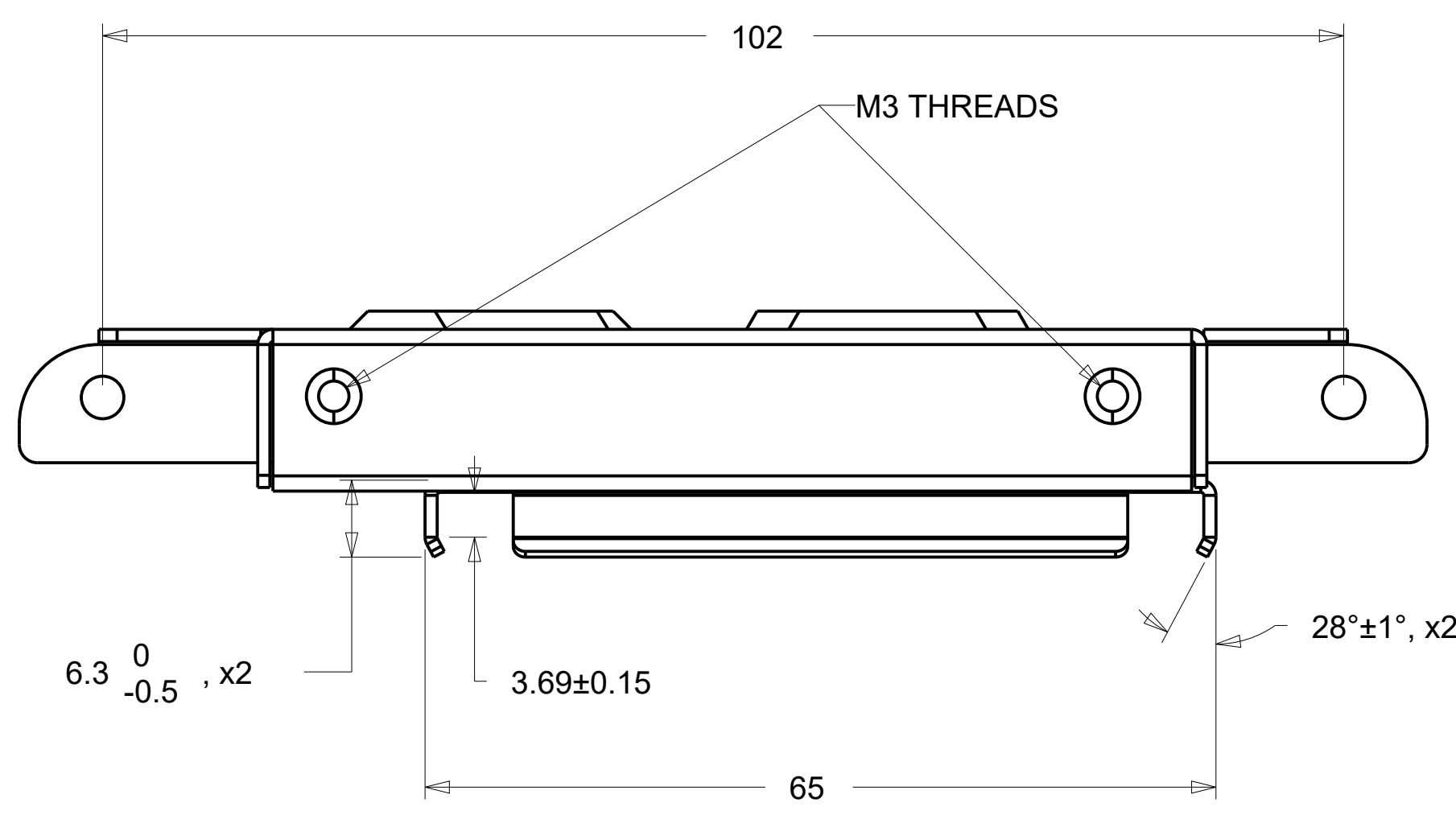
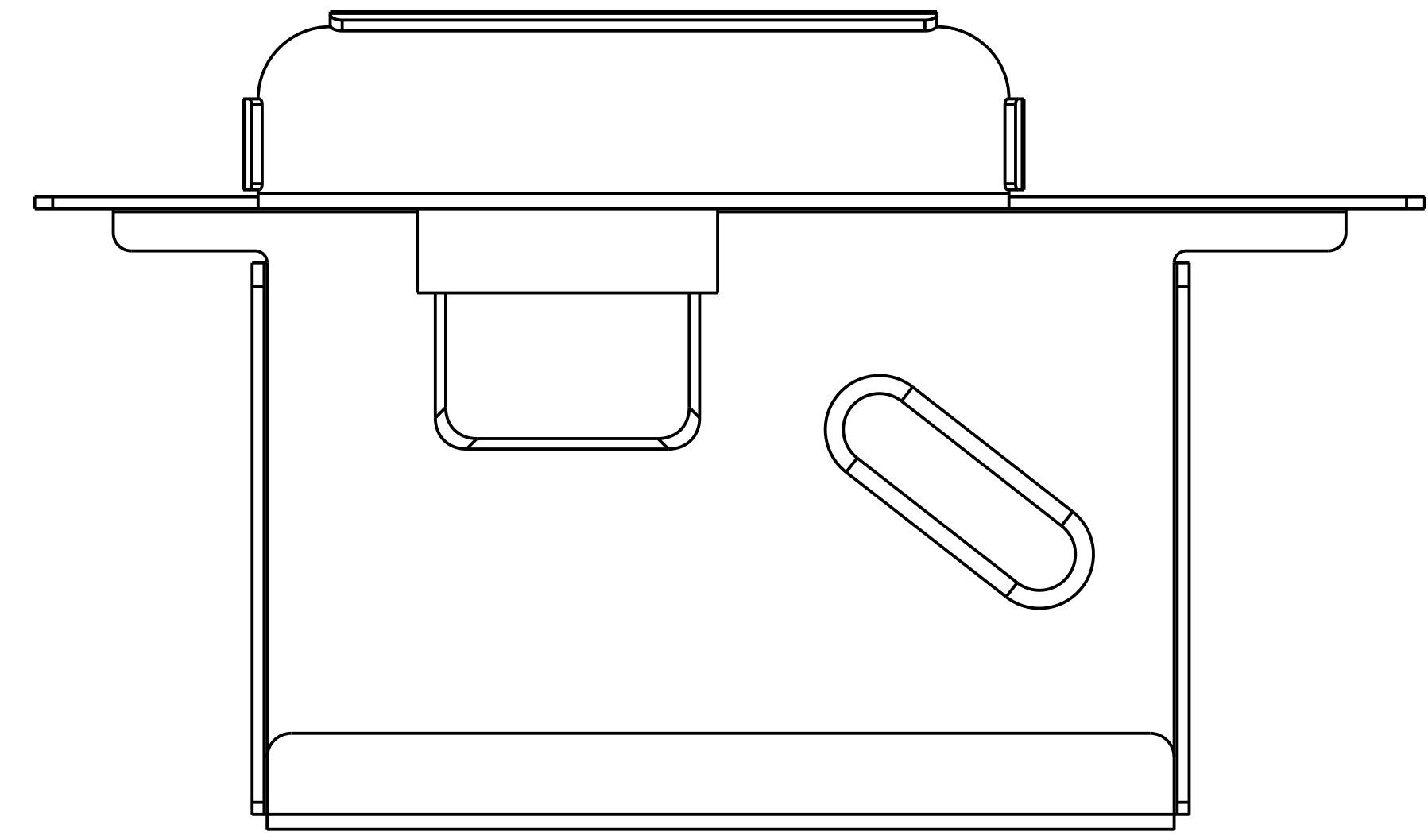
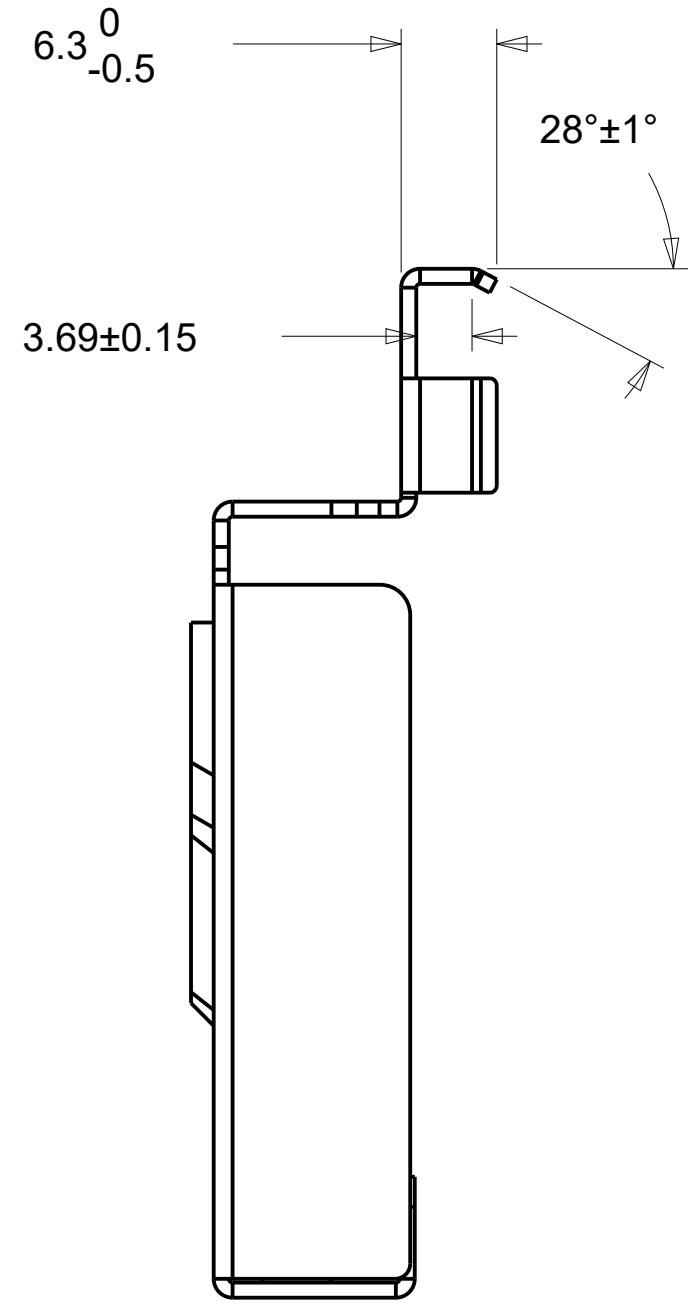
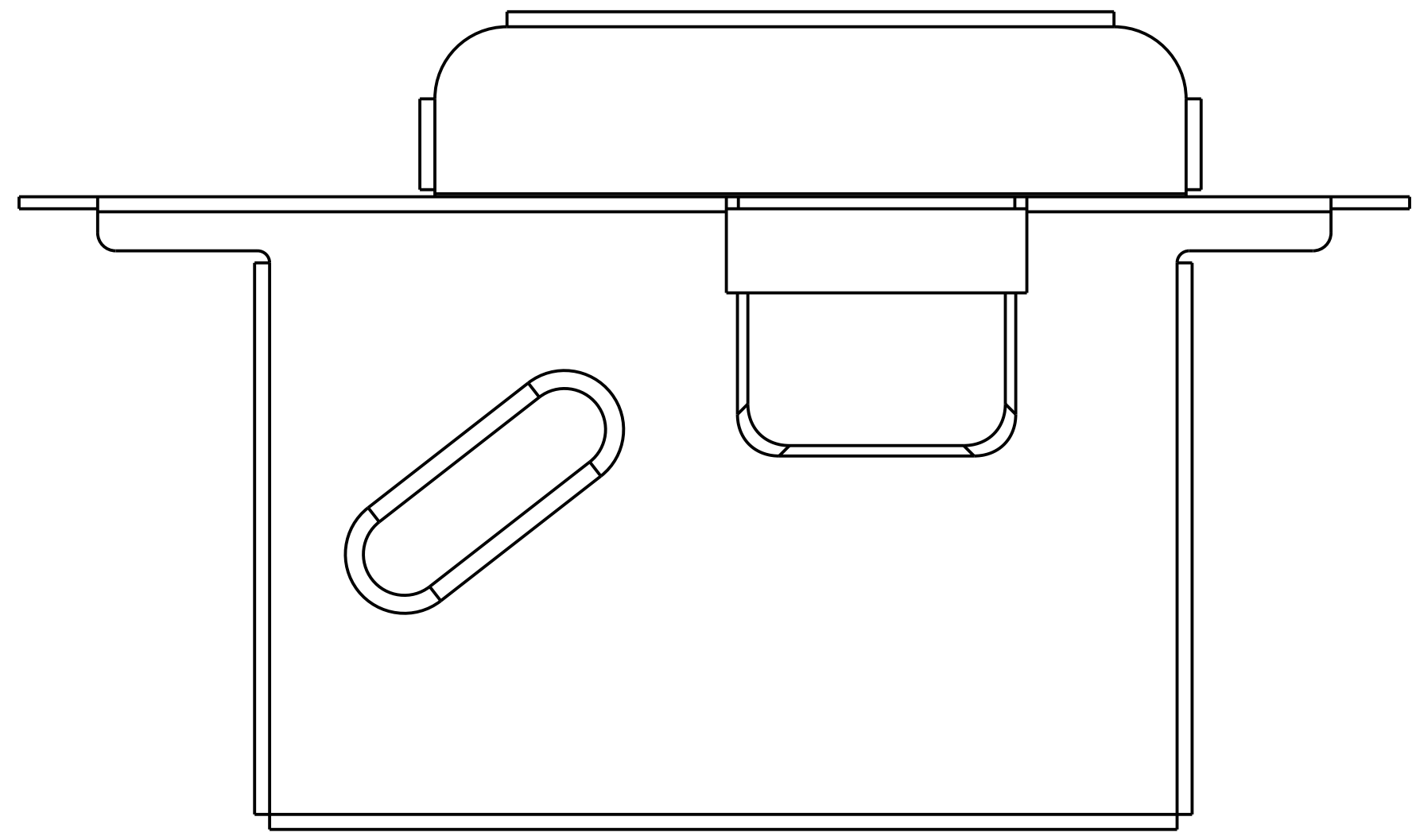



TITLE		FILES MECH, 3D, RP457PP			
SIZE	SCALE	SHEET	DWG. NO.	REV	
D	1.000	3 OF 7	SD608242	3	

DWG. NO. SD608242 SHEET 3 OF 7 REV 3

THIS INFORMATION IS CONFIDENTIAL AND PROPRIETARY TO ELO TOUCH SOLUTIONS. IT MAY NOT BE DISCLOSED TO ANYONE OTHER THAN ELO TOUCH SOLUTIONS PERSONNEL WITHOUT AUTHORIZATION FROM ELO TOUCH SOLUTIONS (www.elotouch.com).

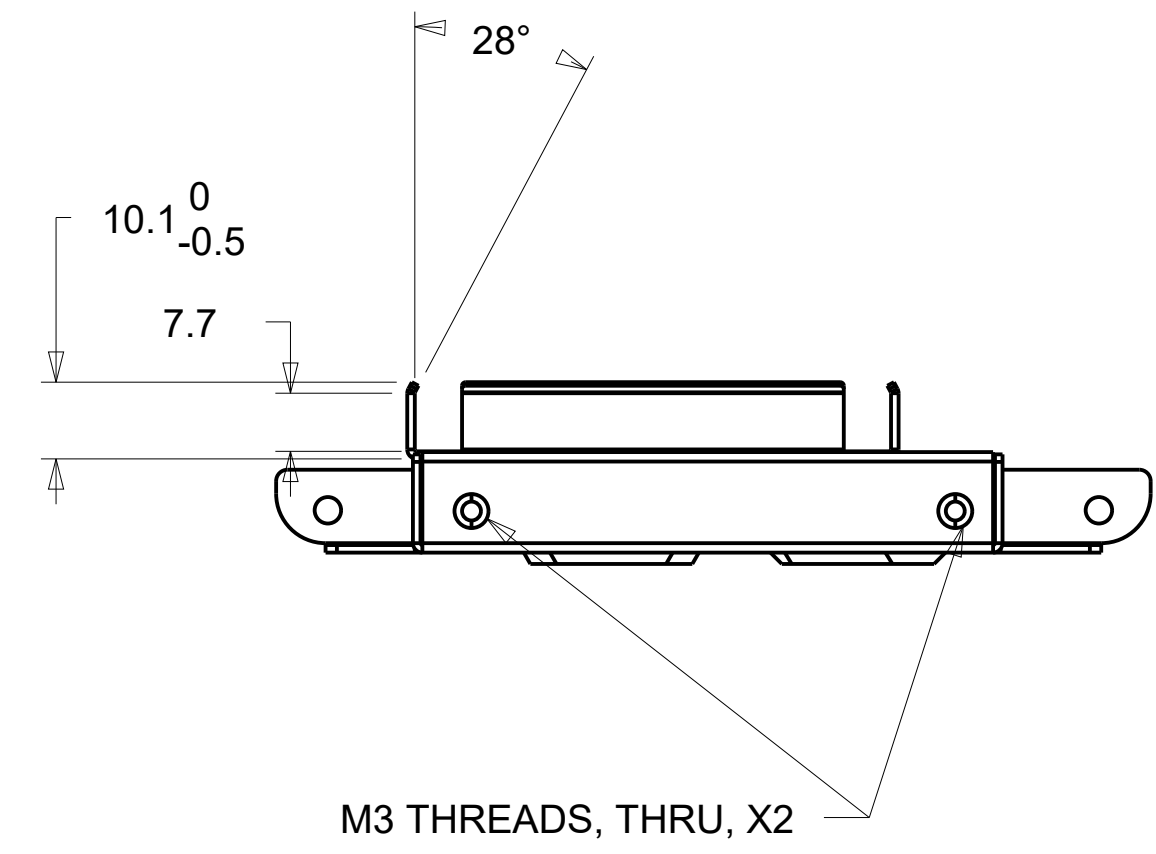
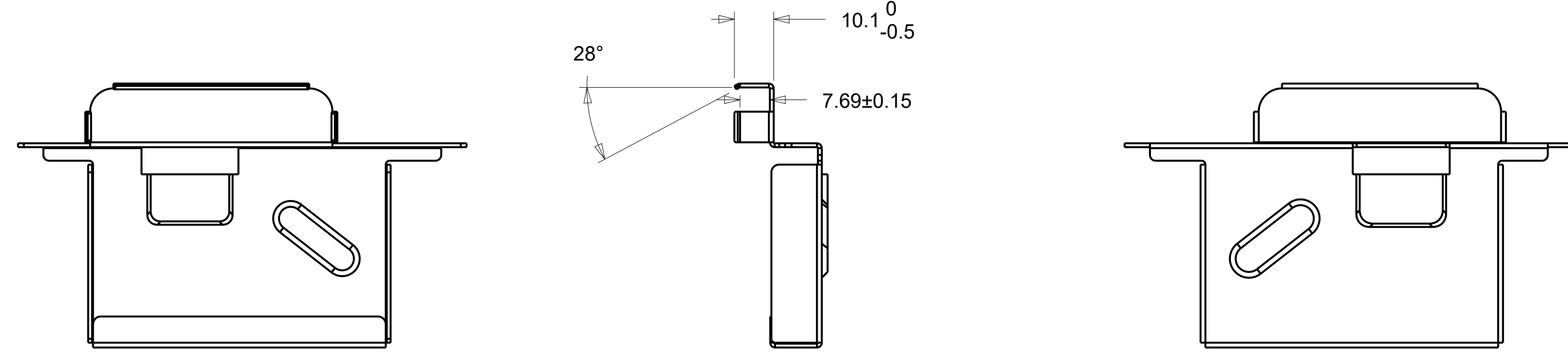
Filename	Material	Finish	Quantity
RP457AUD_BRKT_1.PRT	SECC 1.0T	BLACK PAINT, FINE TEXTURE	1





TITLE		FILES MECH, 3D, RP457PP			
SIZE	SCALE	SHEET	DWG. NO.	REV	
D	1.000	4 OF 7	SD608242	3	

DWG. NO. SD608242
SHT. OF 7
REV. 3

THIS INFORMATION IS CONFIDENTIAL AND PROPRIETARY TO ELO TOUCH SOLUTIONS. IT MAY NOT BE DISCLOSED TO ANYONE OTHER THAN ELO TOUCH SOLUTIONS PERSONNEL WITHOUT AUTHORIZATION FROM ELO TOUCH SOLUTIONS (www.elotouch.com).

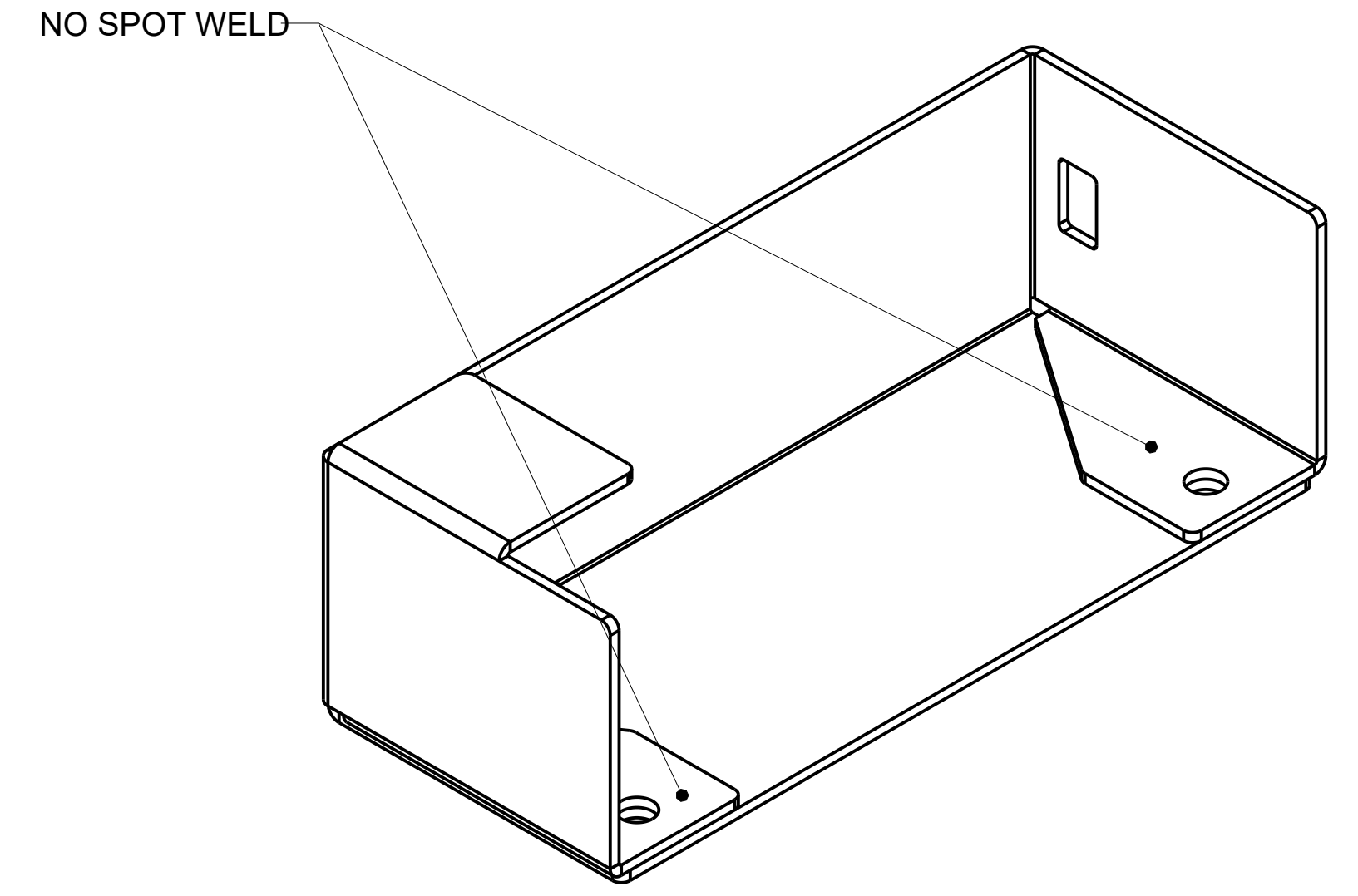
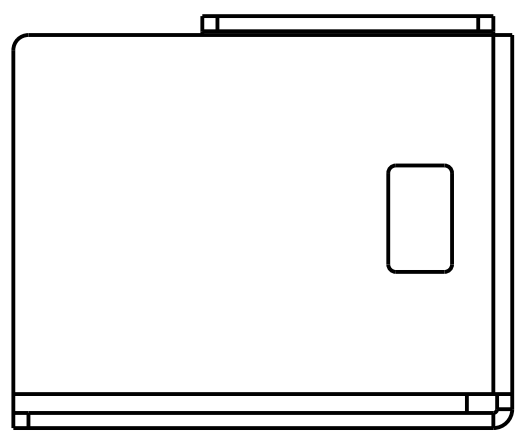
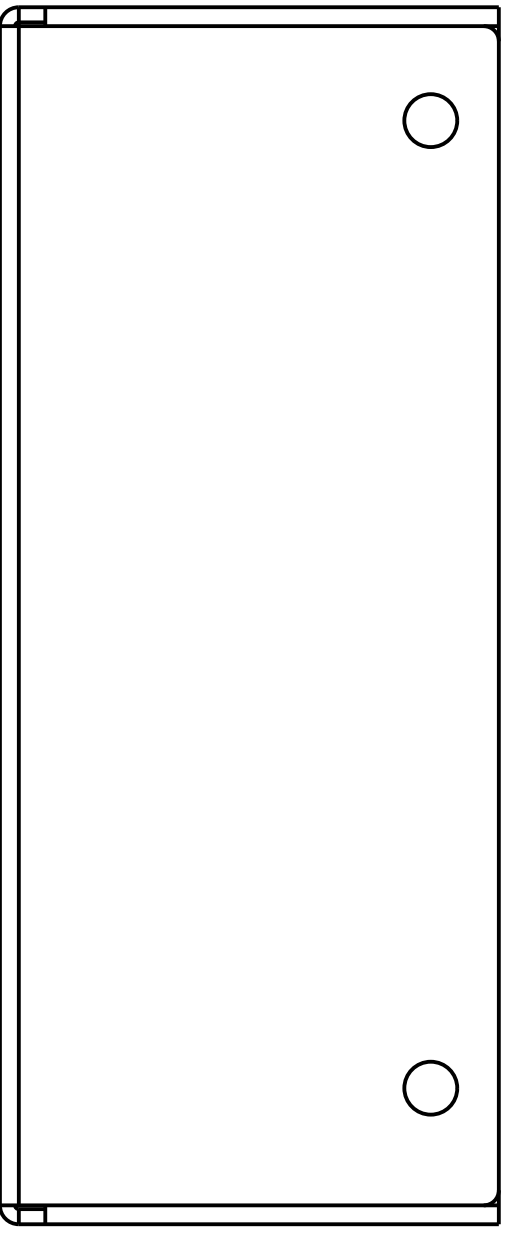
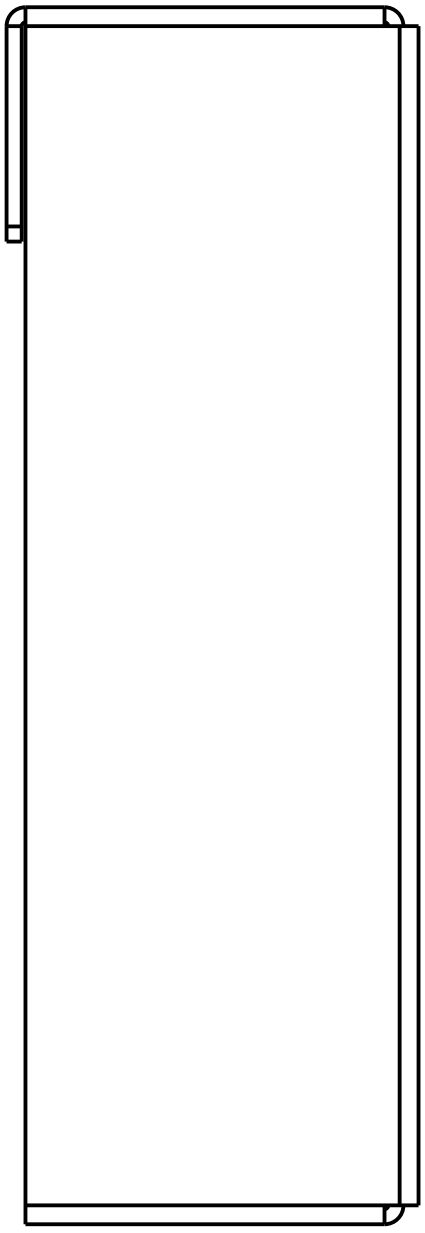
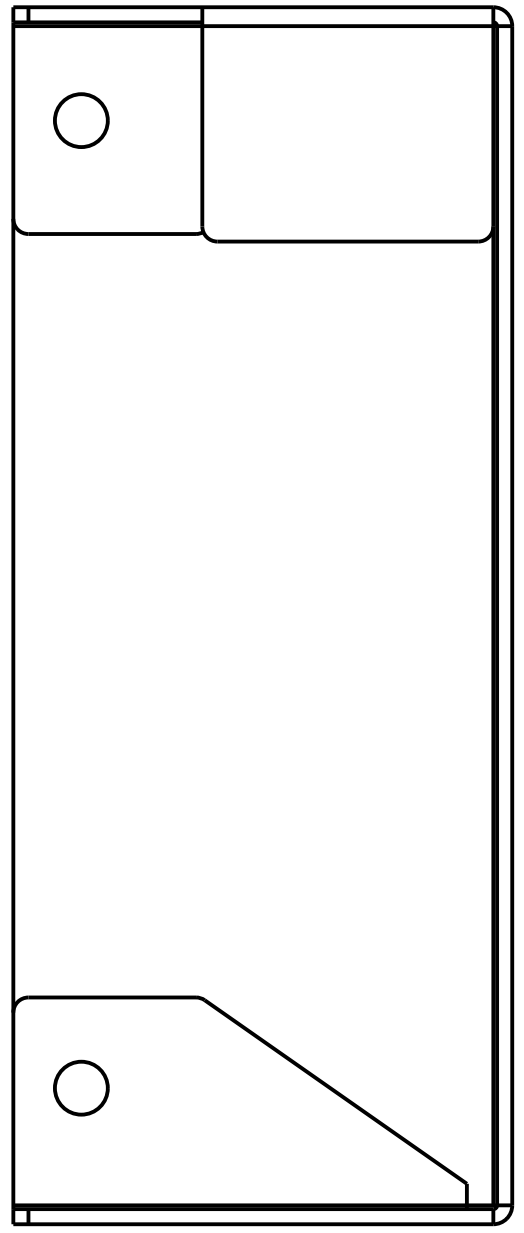
Filename	Material	Finish	Quantity
RP457BT_BRKT_2.PRT	SECC 1.0T	BLACK PAINT, FINE TEXTURE	1





TITLE		FILES MECH, 3D, RP457PP			
SIZE	SCALE	SHEET	DWG. NO.	REV	
D	1.000	5 OF 7	SD608242	3	

DWG. NO. SD608242 REV. 3

THIS INFORMATION IS CONFIDENTIAL AND PROPRIETARY TO ELO TOUCH SOLUTIONS. IT MAY NOT BE DISCLOSED TO ANYONE OTHER THAN ELO TOUCH SOLUTIONS PERSONNEL WITHOUT AUTHORIZATION FROM ELO TOUCH SOLUTIONS (www.elotouch.com).

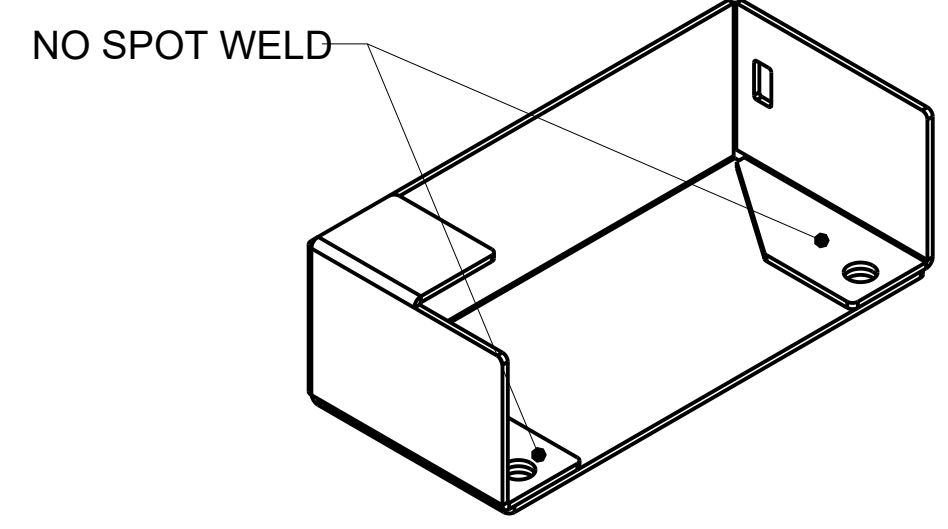
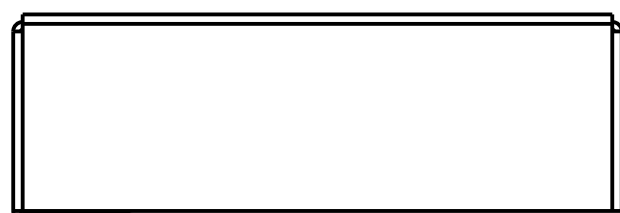
Filename	Material	Finish	Quantity
RP457AUD_BRKT_2.PRT	SECC 1.0T	BLACK PAINT, FINE TEXTURE	1



TITLE		FILES MECH, 3D, RP457PP			
SIZE	SCALE	SHEET	DWG. NO.	REV	
D	1.000	6 OF 7	SD608242	3	

DWG. NO. SD608242

THIS INFORMATION IS CONFIDENTIAL AND PROPRIETARY TO ELO TOUCH SOLUTIONS. IT MAY NOT BE DISCLOSED TO ANYONE OTHER THAN ELO TOUCH SOLUTIONS PERSONNEL WITHOUT AUTHORIZATION FROM ELO TOUCH SOLUTIONS (www.elotouch.com).

Filename	Material	Finish	Quantity
SCREW_M3X6	STEEL	BLACK	2

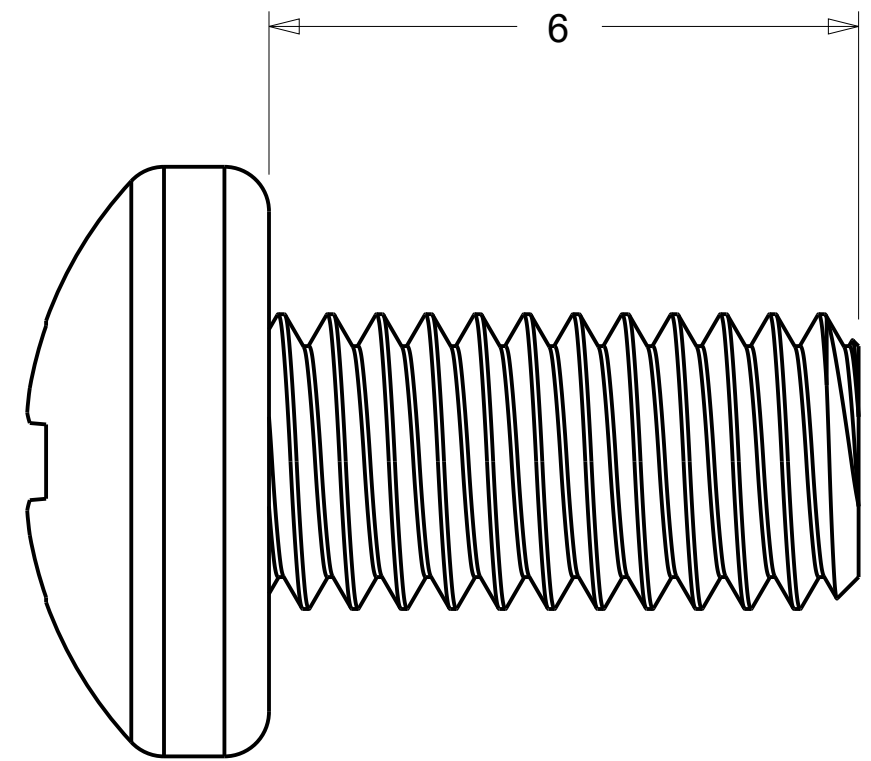
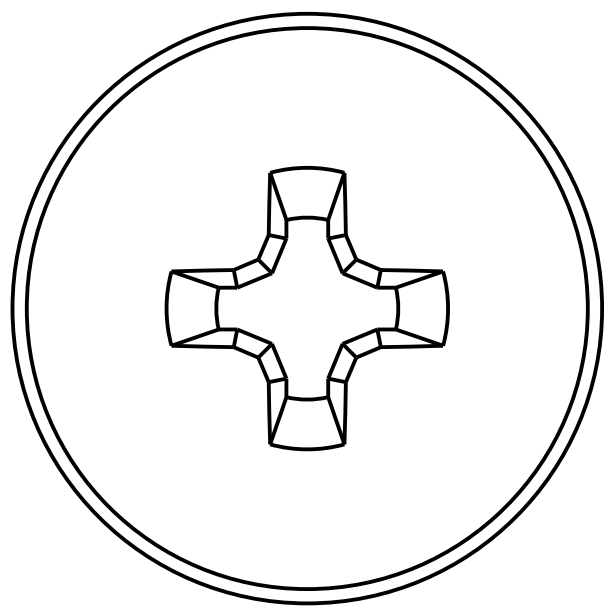

TITLE		FILES MECH, 3D, RP457PP			
SIZE	SCALE	SHEET	DWG. NO.	REV	
D	1.000	7 OF 7	SD608242	3	

DWG. NO. SD608242
SHT. OF 7
REV 3