

Go to www.elotouch.com/support to download user manual.
请访问 www.elotouch.com.cn 获取用户手册
请保留备用

In order to prevent image retention (aka: image sticking, or image burn-in), please use a dynamically changing screensaver or turn off the display when not in use.

Note: Image retention is not covered by your warranty.

No touch driver installation needed

Aucune installation de pilote nécessaire tactile

No hay instalaciones de controlador toque necesario

Kein Touch-Treiber-Installationen notwendig

Nessun driver installazioni tocco necessario

Не прикасаться установок драйвера необходимы

タッチドライバをインストール不要

不需安装触摸驱动程序

不需安装触控驱动程序

필요 없음 터치 드라이버 설치 없음



Quick Installation Guide

IDS 63 Series

Revision A
P/N E403930

Learn more about Elo at EloTouch.com.

Americas

Tel +1 408 597 8000

EloSales.NA@elotouch.com

Europe (EMEA)

Tel +32 16 930 136

EMEA.sales@elotouch.com

Asia Pacific

Tel +86 (21) 3329 1385

EloAsia@elotouch.com

The information in this document is subject to change without notice. Elo Touch Solutions, Inc. and its Affiliates (collectively "Elo") makes no representations or warranties with respect to the contents herein, and specifically disclaims any implied warranties of merchantability or fitness for a particular purpose. Elo reserves the right to revise this publication and to make changes from time to time in the content hereof without obligation of Elo to notify any person of such revisions or changes.

No part of this publication may be reproduced, transmitted, transcribed, stored in a retrieval system, or translated into any language or computer language, in any form or by any means, including, but not limited to, electronic, magnetic, optical, chemical, manual, or otherwise without prior written permission of Elo Touch Solutions, Inc.

Elo and the Elo logo are either trademarks or registered trademarks of Elo Touch Solutions, Inc..



Flush Mount

Bracket shape and quantity varies for each model, drawing for illustration purposes only.

1. Attach bracket "A" to touchscreen monitor (all four sides) with M4 screws (included).
2. Attach bracket "C" to customer panel (all four sides).
3. Attach bracket "B" to bracket "C" on all four sides with M4 screws (included).
4. Adjust depth of bracket "B" so monitor is flush with customer panel.
5. Place touchscreen monitor into customer panel opening.
6. Secure touchscreen monitor to bracket "B" from behind with M4 screws (included).

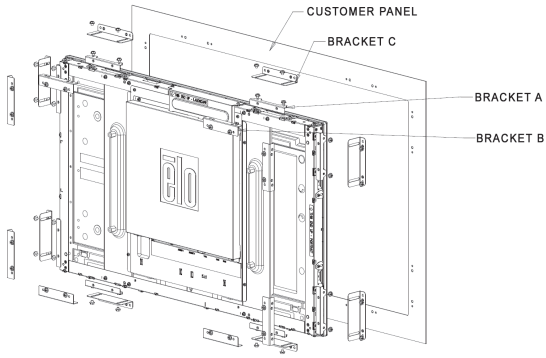

Rear VESA Mount

A VESA-compliant mounting pattern for M6 screws is provided on the rear of the monitor. Pattern varies for each model. Drawing is for illustration purposes only. See dimensional drawing for details.

The VESA FDMI-compliant mounting is coded VESA MIS-F.

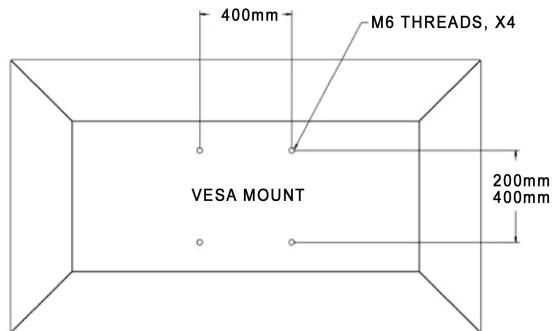

Power



Video



HDMI OR VGA

Touch



OSD



Cover Glass Installation

Elo Open Frame PCAP Touchscreens support protective cover glass. Cover glass must be installed with no air gap to the Touchscreen glass. Touch Thru mode must be enabled to use cover glass.

To enable Touch Thru mode:

1. Press the Menu button on the unit's tethered OSD Remote.
2. Navigate to Miscellaneous -> Touch -> Touch Thru.
3. Set to "On".
4. Add cover glass on top of touchscreen.
5. Power cycle the monitor.

If the cover glass is later removed, this feature should be set to "Off" and the monitor power cycled for the touchscreen to work correctly.

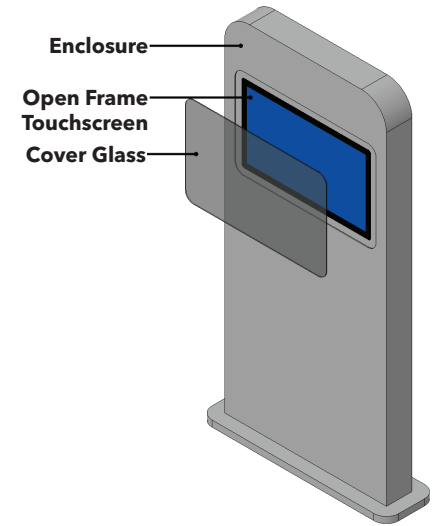

Problem	Troubleshooting
Monitor display is dim	- Use the OSD to increase the brightness &/or contrast.
Monitor display is blank	- If the Power Status LED is blinking, the monitor or Computer Module maybe in Sleep mode. Press any key / move the mouse / touch the touchscreen to see if the image reappears. - Check that there are no loose cable connections.
Monitor image looks strange or is displaying an "Out of Range" message	- Adjust your computer's resolution/timing mode to be within the allowable timing ranges specified for your touchscreen display. - Use the Auto Adjust function in the OSD.
Touch functionality doesn't work	- Verify your PC has the latest Elo drivers installed. - Perform the calibration routine provided with the Elo drivers. - If the OSD buttons or power button does not respond, check to see if the OSD lock or power lock functions is on.
Can't wake on touch	- Check to see if the OSD Touch on Sleep function is disabled.
Only supports two touches at a time	- Check to see if the OSD Touch Thru function is on.